

BILL OF MATERIALS

- (2) 2" x 4" x 96" Studs
- (1) 30" x 42" 3/4" Plywood

NOTES:

TAPERING THE LEGS ISN'T NECESSARY BUT IT ONLY TAKE A FEW EXTRA CUTS AND LOOKS MUCH BETTER.

ALSO THREE LEGS MAKE IT GREAT FOR UNEVEN GROUND BUT NOT AS STABLE AS 4 IF YOU'RE GOING TO KEEP IT AS FURNITURE

STANDING OR SITTING:

THESE PLANS MAKE A TABLE AT STANDARD SITTING HEIGHT. IF YOU WANT A STANDING HEIGHT DESK FOR THE JOBSITE ADD ABOUT 10 INCHES TO ALL THE LEG LENGTHS. DEPENDING ON YOUR HEIGHT.

I'D START BY CUTTING ONE FRONT LEG FIRST, THEN USING IT AS A TEMPLATE FOR THE SECOND FRONT LEG TO MAKE SURE THEY ARE UNIFORM.

TAKING YOUR TIME AND USING A NICE HARDWOOD THIS DESIGN COULD MAKE A NICE FURNITURE PIECE.

THANKS,
COLLIN



IF YOU BUILD YOUR OWN PLEASE SHARE IT ON INSTAGRAM: RAAZDESIGNLLC,
I'M CURIOUS TO SEE WHAT OTHER PEOPLE DO WITH THE DESIGN.

ALSO IF YOU NOTICE ANYTHING THAT NEEDS TO BE ADDED TO THESE PLANS PLEASE LET ME KNOW SO I
CAN UPDATE THEM.

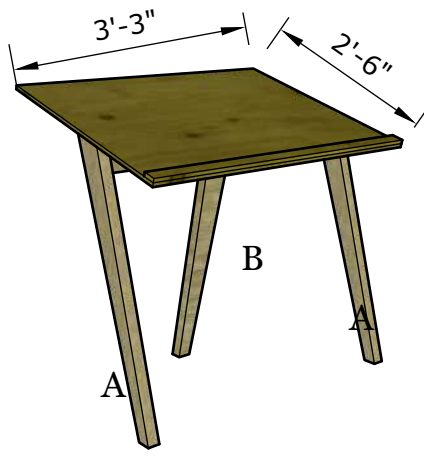

FRONT PERSPECTIVE

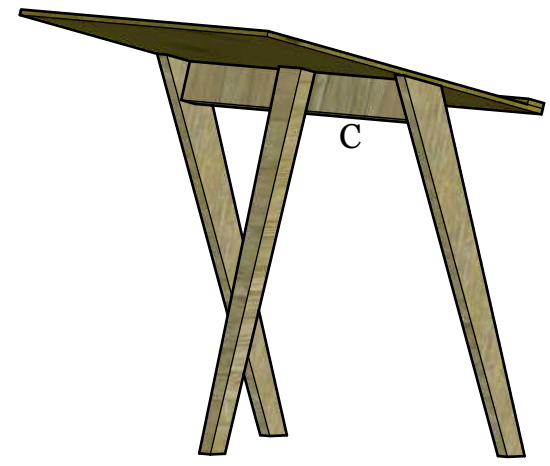

BACK PERSPECTIVE

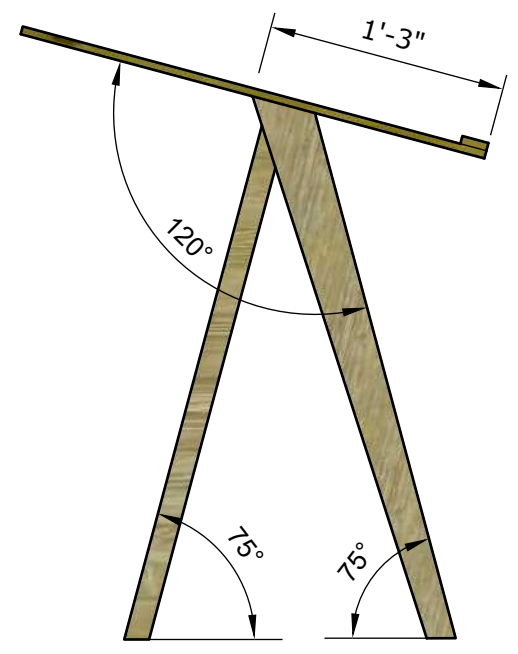

FRONT LEGS

BACK LEG

STRINGER

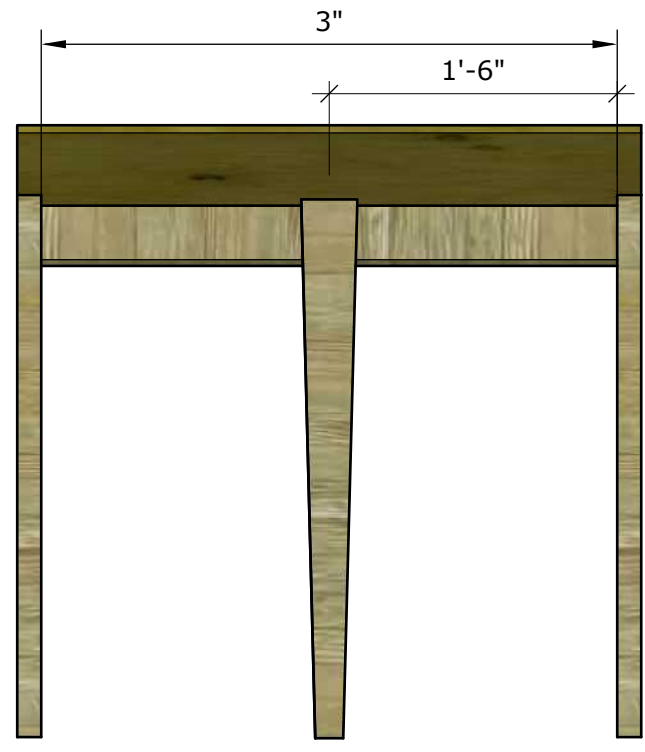
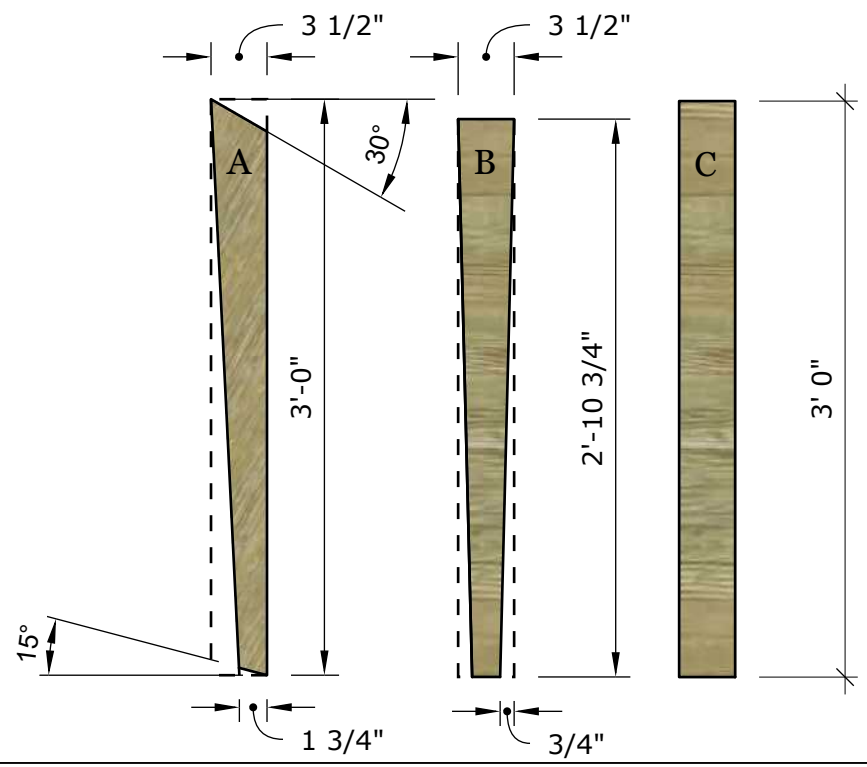

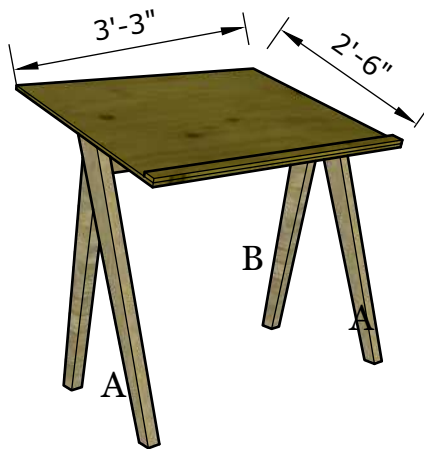

FRONT PERSPECTIVE

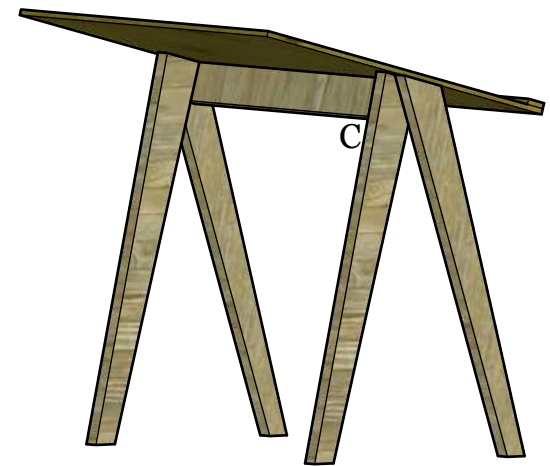

BACK PERSPECTIVE

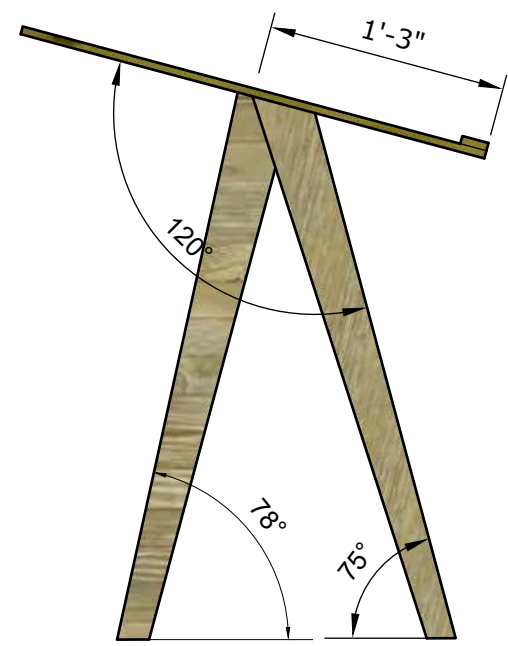

FRONT LEGS

BACK LEG

STRINGER

